

## Hop Air Fryer Pro Model: EFE475PRO

Hop Air Fryers deliver the quality your customers can see - improving profits and health at an affordable price.



### Standard Features

- 2 International patents
- Digital Control panel
- Stackable (With optional stacking kit)
- Rotating Basket – 3.5lb capacity
- Condensation emission removal system
- Carbon filter for odor removal
- USB port – up to 99 menu items
- Self cleaning

### Optional Accessories

- Teflon Cooking Tray Part #EFEPT50
- Stacking Kit Part #EFESK30
- Spray Down Hose Assembly Part #EFES1
- Carbon Filter Part #EFEGF1
- Stainless Steel Equipment Stand Part #EFESVET3630
- Stainless Steel Freezer Base Part #EFELBFD8230S

---

### Standard Items Included

- Install Kit
- 2 Rotating stainless steel baskets
- 1 Teflon tray
- 2 Extractor Handles
- 1 Carbon filter
- 1 Cooking Grid GN 2/3
- 1 Gallon Detergent

### Weight & Size

- 115lbs.
- 27-3/4" x 31-3/4" x 21-7/8" (W X D X H)

### Contact Us:

Visit: [ecofryequipmentllc.com](http://ecofryequipmentllc.com)

Email: [kraymond@ecofryequipment.com](mailto:kraymond@ecofryequipment.com)

## Hop Air Fryer Pro Model: EFE475PRO

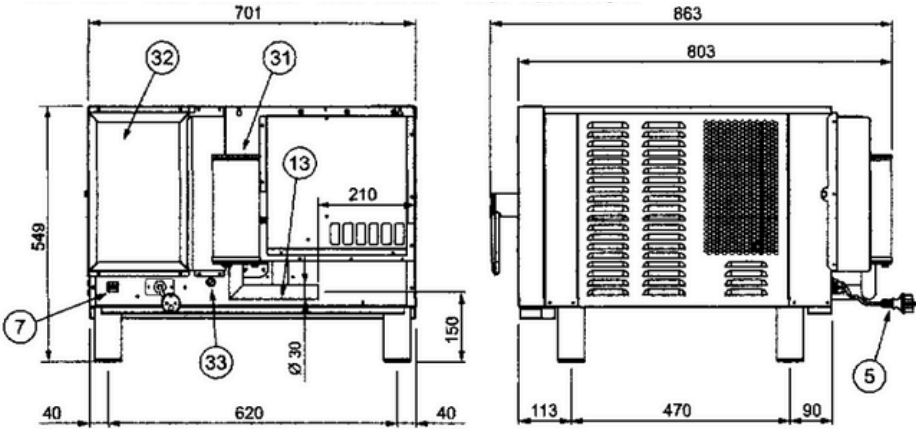

HOP - HOP.P

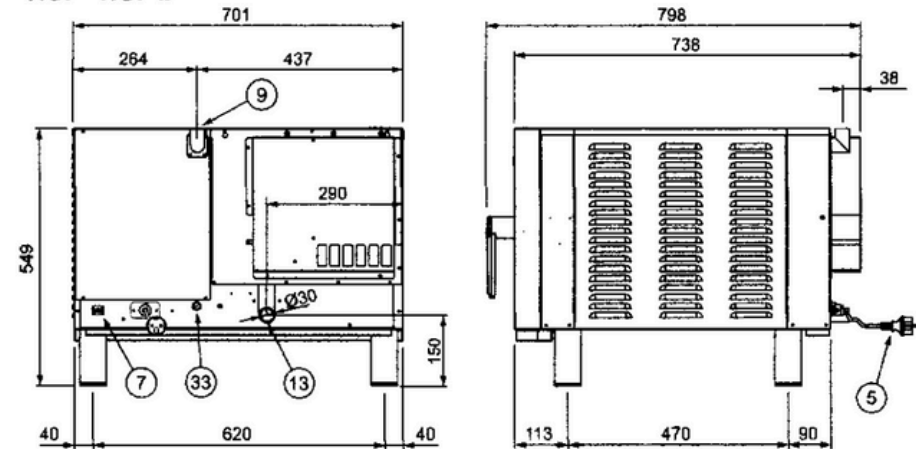

5	Power cable	31	Carbon filter
7	Equipotential terminal	32	Air filter
9	Smoke outlet flue	33	Safety thermostat
13	Drain pipe		

<b>Power Requirements</b>	208V-240V
<b>Phase</b>	Single
<b>Amps</b>	24
<b>Breaker</b>	30 Amp
<b>KW</b>	4.75
<b>Plug</b>	NEMA LP6-30
<b>Receptacle</b>	NEMA L6-30R
<b>Clearences</b>	4" L, R & Rear
<b>Drain</b>	1-1/8" Connection
<b>Water Inlet</b>	8mm OD Tubing

All connections must comply with federal, state and local codes.

### Contact Us:

Visit: [ecofryequipmentllc.com](http://ecofryequipmentllc.com)

Email: [kraymond@ecofryequipment.com](mailto:kraymond@ecofryequipment.com)